

# DUMBBELL RACKING ASSEMBLY INSTRUCTIONS

## 12 PAIR RACK

To ensure that your racking is assembled correctly, please follow these instructions carefully. All letters in brackets on this page refer to the 'Part No.' on the reverse 'PART LISTING' page.

**Step 1:** Bolt Cross Piece (C) to Legs (A) as shown. This **must** be done first, before proceeding with any other assembly. **Do not** fully tighten any bolts until entire rack has been assembled. Take note of the information on "Plastic Bolt Head Covers" on page 3.

**Note:** Legs (A) can be used in any position - there is no specific outside leg.

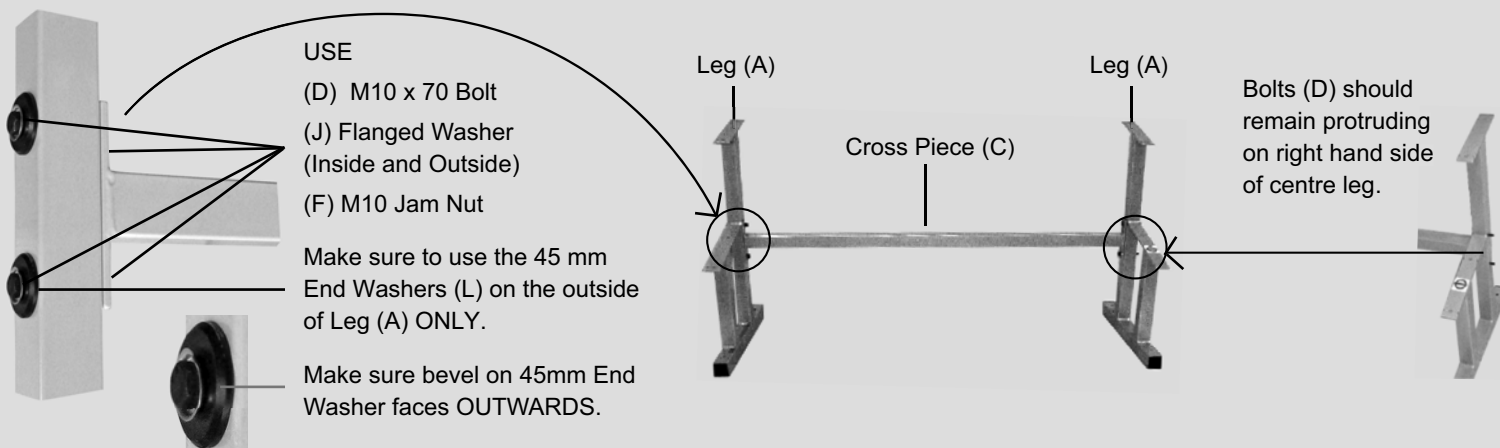

**Step 2:** Fit the Dumbbell Supports (B) to Legs (A). This can be done in any order. Take note of the stickers on the Dumbbell Supports to determine where each Dumbbell Support (B) sits on the Legs (A) and that they are orientated correctly – there are different supports for the front and back of the top and bottom tiers. This is much easier to do with 2 people – one to hold the supports in place, the other to insert bolts etc.



Position the Dumbbell Support (B) on the legs (A) aligning the bolt holes as pictured. Push the Bolt (H) into place (make sure there is a Flanged Washer (J) underneath the bolt head) and tighten. For the center leg, no nut or washer is required as bolt fixes to threaded Metal Adaptor Plate (N). Fix to the outside Leg (A) using a Bolt (H) and Nut (G) and Washer (E) on the underside (again use a Flanged Washer (J) underneath bolt head).

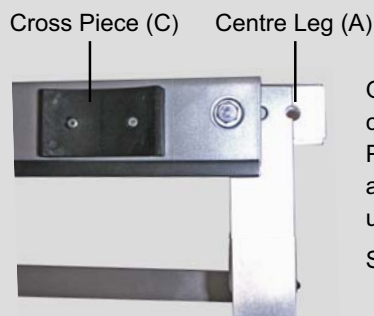

On the Leg (A) being used in the center, align the Plastic Adaptor Plate (M) underneath the Leg (A) and the Metal Adaptor Plate (N) underneath that as pictured.

See side-view picture on page 3.

Repeat **Step 2** for the other 3 dumbbell supports, rack should now appear as above. Once this is done, repeat the above steps for the right hand side of the rack. Make sure to fix the 2nd Cross Piece (C) to the right-hand outside leg before fitting the Dumbbell Supports (B). Once fully assembled, firmly tighten all bolts using two 16mm spanners (not supplied). Push all Plastic Bolt- Head Covers (K) into place.

USE

for outer legs and inside leg

(H) M10 x 25 Bolt

(J) Flanged Washer (on top)

(E) M10 Zinc Washer (underneath, outside leg only)

(G) M10 Zinc Nut (underneath, outside leg only)

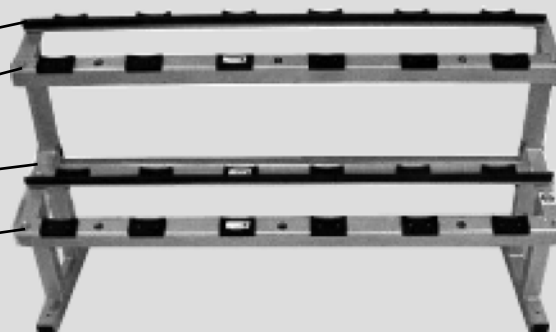

1

# DUMBBELL RACKING ASSEMBLY INSTRUCTIONS

## 12 PAIR RACK

### PLASTIC BOLT HEAD COVERS (K)

**NOTE:** Your Australian Barbell Racking has been supplied with special Plastic Bolt-Head Covers (K). These are used to cover **all** bolt heads only as well as nuts used to attach the Legs (A) to Cross Piece (C). They are **not** used to cover the Nuts (G) used on the underside of the Dumbbell Supports (A). When assembling racking, please follow these instructions to ensure they are fitted correctly.

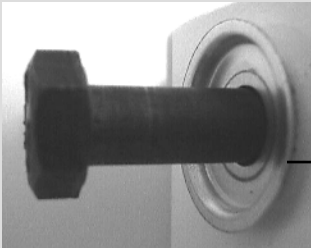

- i) Ensure that the flange on the Flanged Washer (J) is facing upwards and on the side that the head of the bolt will be on.
- ii) After all bolts have been fully tightened, push the Plastic Bolt-Head Cover (K) down onto the steel washer and it will snap into place.











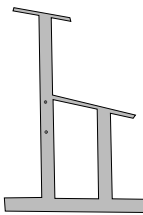

- Leg (A)
- Plastic Adaptor (M)
- Metal Adaptor Plate (N)

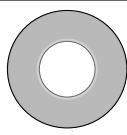
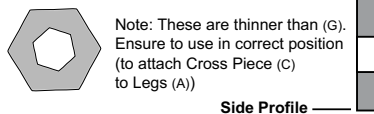

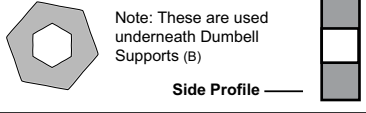
# DUMBBELL RACKING PART LISTING

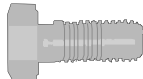
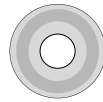
Please check from the list below that you have received all components required to correctly assemble your rack.

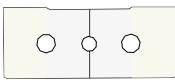
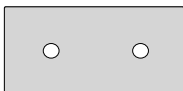
Part	Picture (Not to scale)	Description	Qty per rack			
			6 Pair	8 Pair	10 Pair	12 Pair
A		Legs	2	2	3	3
B	 Note: No. of cushions on rack will vary depending on no. of dumbbells it holds.	Dumbbell Supports	4 (1.5m long)	4 (2m long)	4 (2.5m long)	8 (1.5m long)
C		Cross Piece	1 (1.4m long)	1 (1.9m long)	2 (1.175m long)	2 (1.425m long)
D		M10 x 70 Bolt	4	4	6	6
E		M10 Zinc Washer	8	8	12	8
F	 Note: These are thinner than (G). Ensure to use in correct position (to attach Cross Piece (C) to Legs (A)) Side Profile — 	M10 Zinc Jam Nut	4	4	6	6
G	 Note: These are used underneath Dumbbell Supports (B) Side Profile — 	M10 Zinc Nut	8	8	12	8
H		M10 x 25 Zinc Bolt	8	8	12	16
J		Flanged Washer (Silver)	16	16	24	28
K		Plastic Bolt-Head Cover	16	16	24	28
L		45 mm End Washer	4	4	4	4
M		Plastic Adaptor Plate	0	0	0	4
N		Metal Adaptor Plate	0	0	0	4